

UNDERGROUND UTILITIES
 CALL
 2 WORKING DAYS
 BEFORE YOU DIG
 CALL TOLL FREE 800-362-2764
 OHIO UTILITIES PROTECTION SERVICE

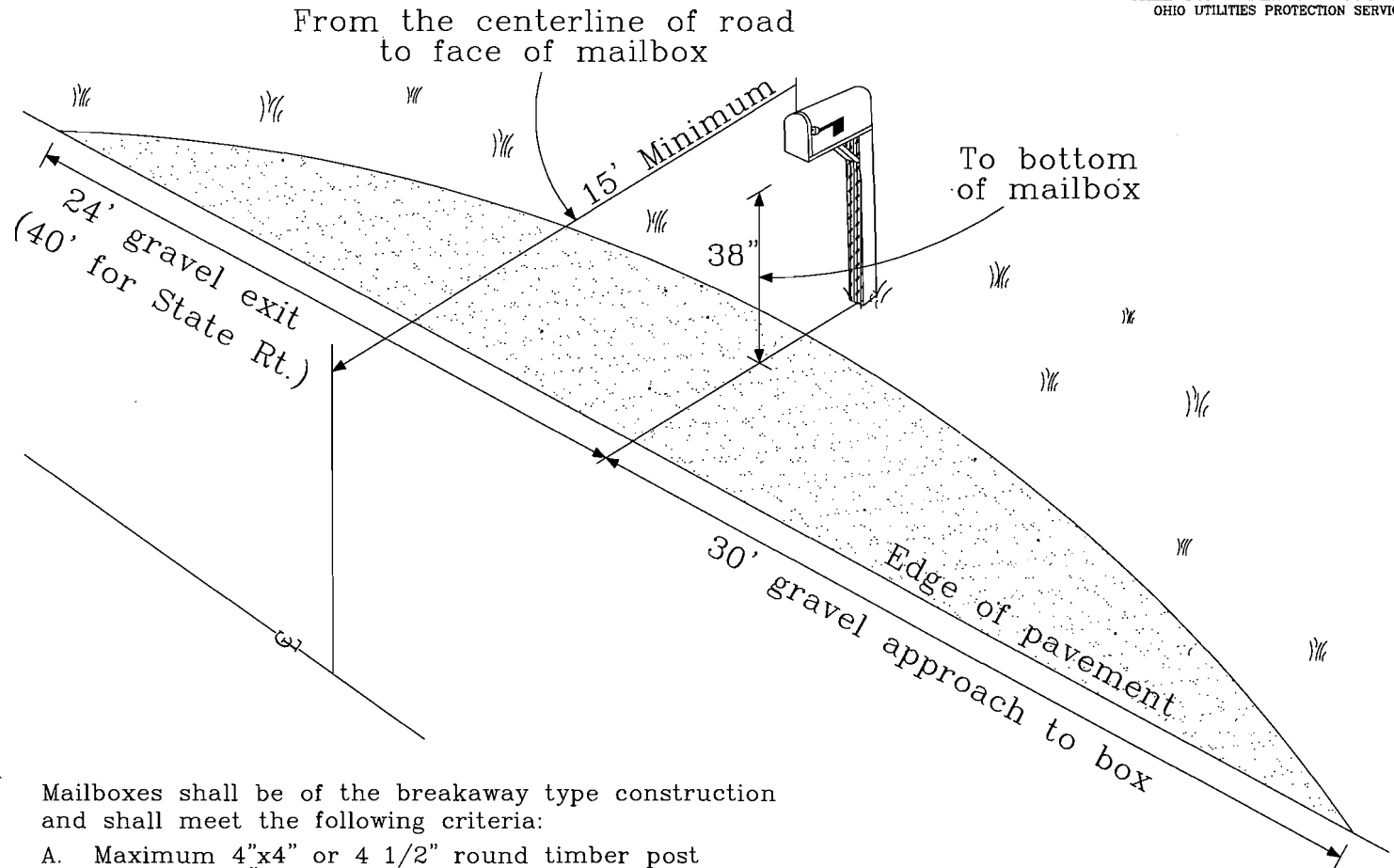

Mailboxes shall be of the breakaway type construction and shall meet the following criteria:

- A. Maximum 4"x4" or 4 1/2" round timber post
- B. Maximum 2" I.D. nominal pipe size steel post
- C. Boxes shall be no larger or heavier than the U.S. postal standards.

MAILBOX POSTS SHALL NOT BE SET IN CONCRETE!!

STANDARD MAILBOX INSTALLATION

Pickaway County Engineer

Dep. Pickaway County Engineer

Approved:

Revised

Standard Mailbox Installation

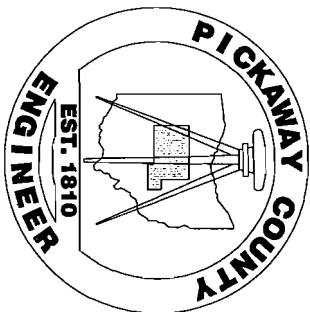

UNDERGROUND UTILITIES
 CALL
 2 WORKING DAYS
 BEFORE YOU DIG
 CALL TOLL FREE 800-362-2764
 OHIO UTILITIES PROTECTION SERVICE

Mailboxes shall be of the breakaway type construction and shall meet the following criteria:

- A. Maximum 4"x4" or 4 1/2" round timber post
- B. Maximum 2" I.D. nominal pipe size steel post
- C. Boxes shall be no larger or heavier than the U.S. postal standards.

MAILBOX POSTS SHALL NOT BE SET IN CONCRETE!!

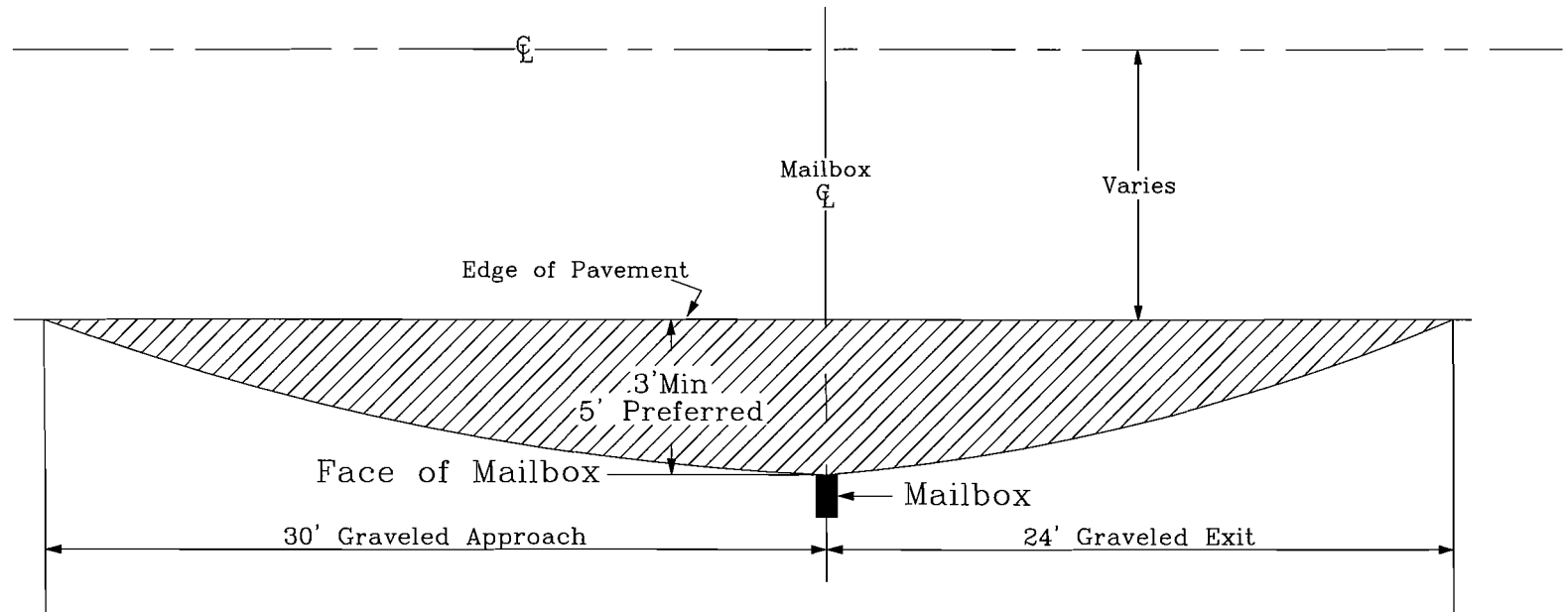

STANDARD MAILBOX APPROACH

Pickaway County Engineer

Dep. Pickaway County Engineer

Approved:

Revised

**Mailbox Approach
 Standards**

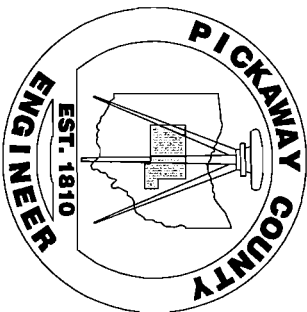

UNDERGROUND UTILITIES
 CALL
 2 WORKING DAYS
 BEFORE YOU DIG
 CALL TOLL FREE 800-362-2764
 OHIO UTILITIES PROTECTION SERVICE

Mailboxes shall be of the breakaway type construction and shall meet the following criteria:

- A. Maximum 4"x4" or 4 1/2" round timber post
- B. Maximum 2" I.D. nominal pipe size steel post
- C. Boxes shall be no larger or heavier than the U.S. postal standards.

MAILBOX POSTS SHALL NOT BE SET IN CONCRETE!!

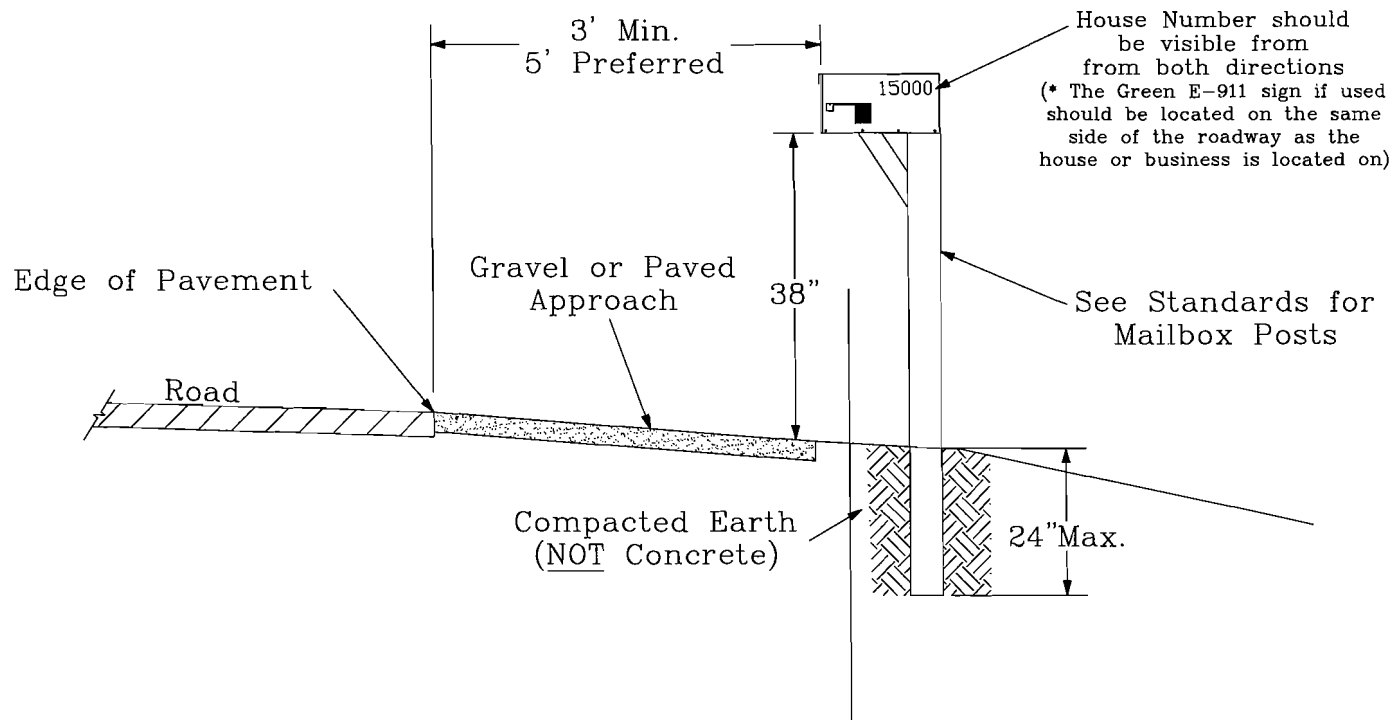

MINIMUM STANDARDS FOR URBAN/RURAL ROADSIDE MAILBOX

Pickaway County Engineer

Dep. Pickaway County Engineer

Approved:

Revised

**Standard
 Urban/Rural
 Mailbox Installation**

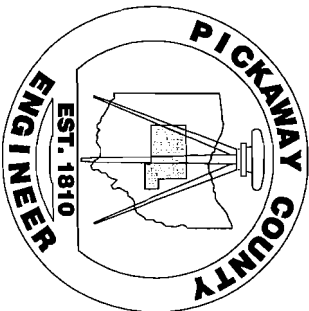

UNDERGROUND UTILITIES
 CALL 2 WORKING DAYS BEFORE YOU DIG
 CALL TOLL FREE 800-362-2764
 OHIO UTILITIES PROTECTION SERVICE

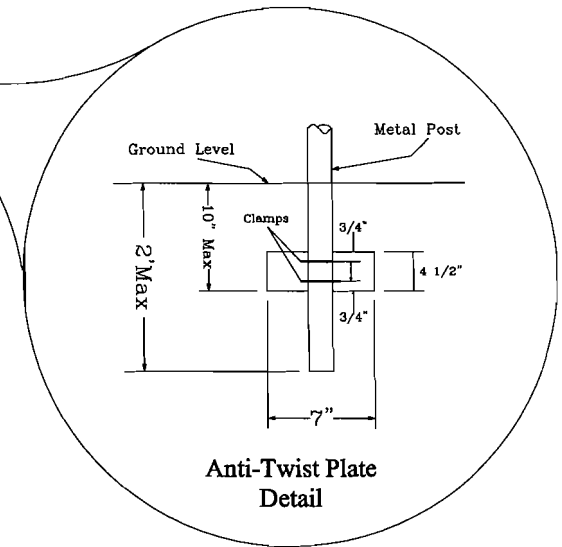
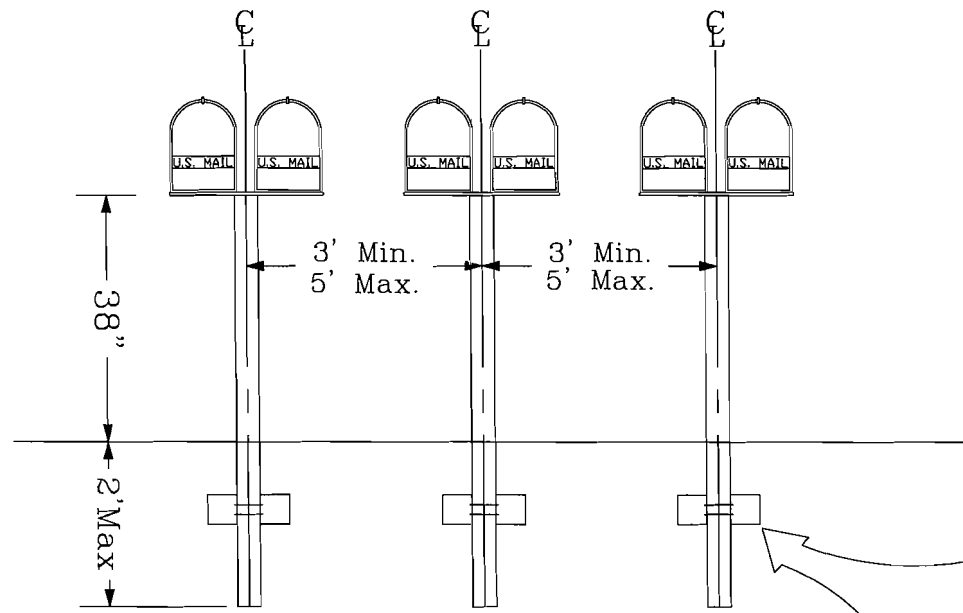

Mailboxes shall be of the breakaway type construction and shall meet the following criteria:

- A. Maximum 4"x4" or 4 1/2" round timber post
- B. Maximum 2" I.D. nominal pipe size steel post
- C. Boxes shall be no larger or heavier than the U.S. postal standards.

MAILBOX POSTS SHALL NOT BE SET IN CONCRETE!!

GROUP MAILBOXES WITH ANTI-TWIST PLATES (METAL POSTS ONLY)

Pickaway County Engineer

Dep. Pickaway County Engineer

Approved:

Revised

Standard Group Mailbox Installation

